

New product

CONDUCTOR RAIL CLEANING DEVICE

ARG 14 DS



GENERAL INFORMATION

The cleaning device Model ARG 14 DS cleans conductor rails with a conductor spacing of 14 mm (U10) automatically and preventive from dust deposits.

The cleaning device consists of a side channel blower (230/400 V) with filter housing and a suction head equipped according to the number of poles/conductors. It is to be mounted to the overhead monorail system carrier (by others).

Cleaning elements are installed to collectors instead of carbon brushes.

Technical data

Power:	0.37 kW 230/400 V three-phase current 50 Hz (other motors available)
Power consumption:	1.6/1 A
Starting current:	max. 6 A
Air throughput:	1.300 L/min
Vacuum:	850 mm/water column
Operating noise:	67 dB (A)
Weight:	9.4 kg

Cleaning device

The following standard versions of the cleaning device are available:

Model ⁽¹⁾	Conductor rail	Number of poles	Order No.
ARG 14-6 DS	U10	6	142 545
ARG 14-7 DS	U10	7	142 601
ARG 14-8 DS	U10	8	142 538

Further models for different numbers of poles/conductors, conductor spacings and conductor rail systems available upon request.

Cleaning device ARG 14 DS for U10 conductor rails

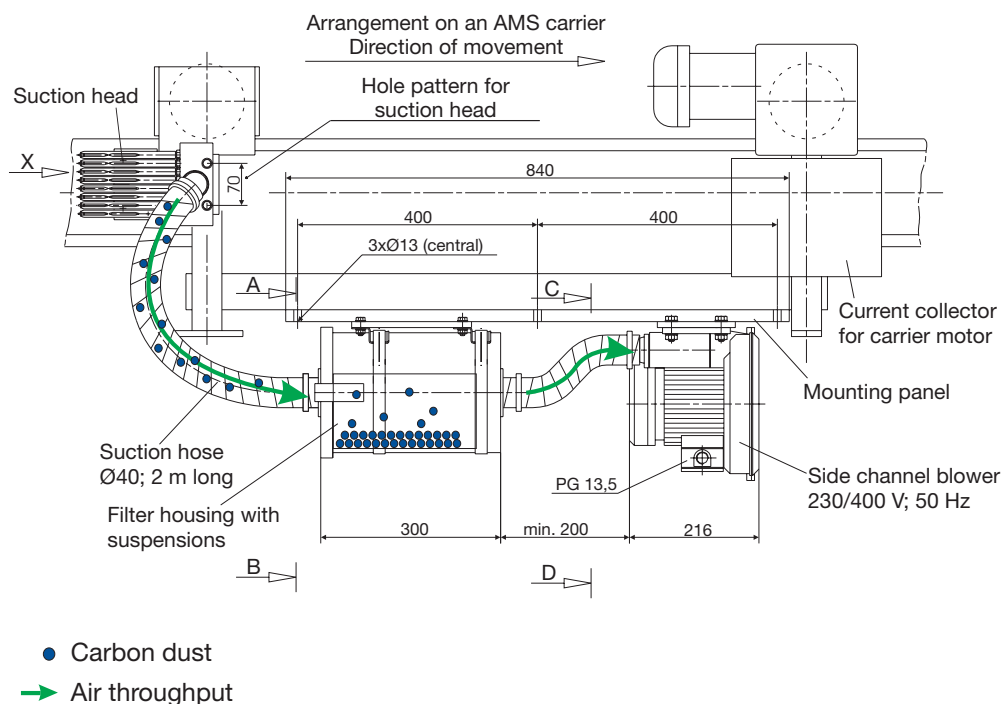

SUCTION HEAD

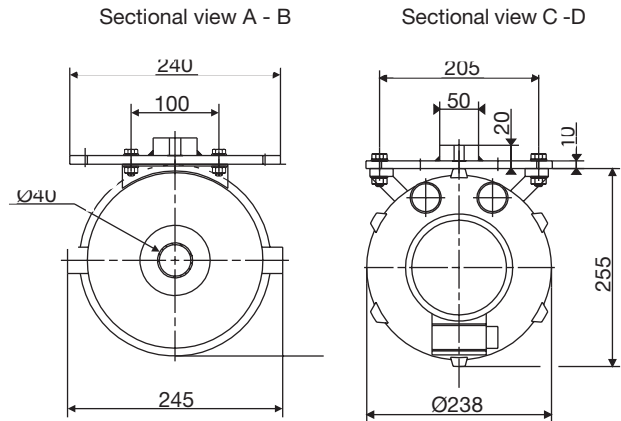
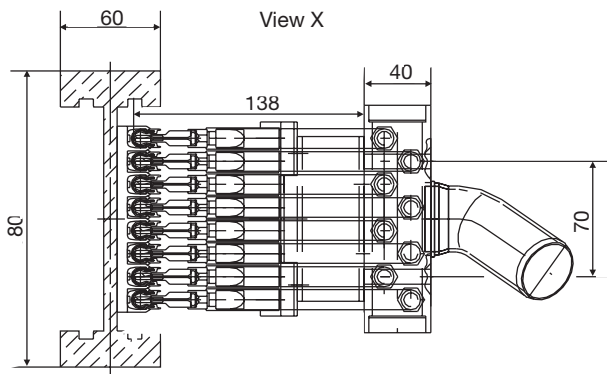

Suction head



The following suction heads are available for the cleaning devices:

Suction head for cleaning device Model	with compact rail cleaner	Order No.
ARG 14-6 DS	ARDS 2/40-6-14	142 546
ARG 14-7 DS	ARDS 2/40-7-14	142 603
ARG 14-8 DS	ARDS 2/40-8-14	142 539

Further models for different numbers of poles/conductors, conductor spacings and conductor rail systems upon enquiry.

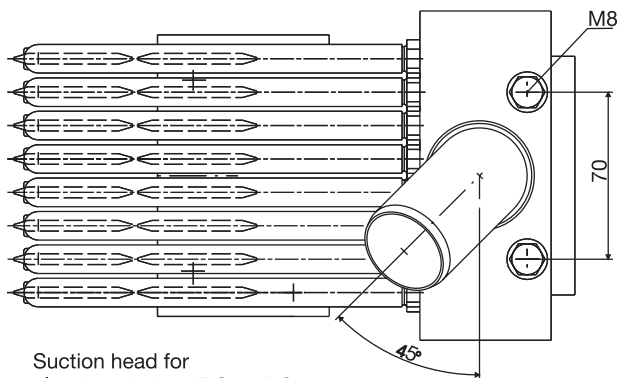

Suction head for cleaning device ARG 14 DS

8-pole type

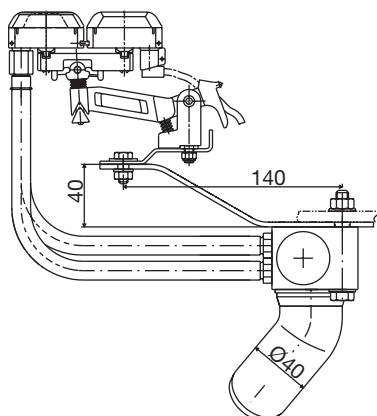
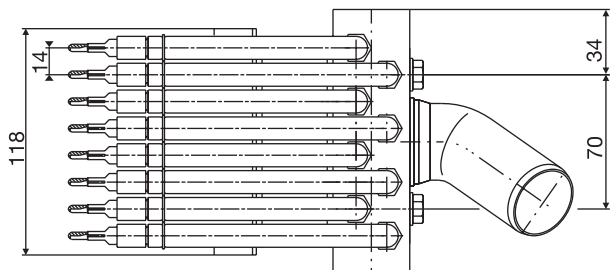

6-pole type

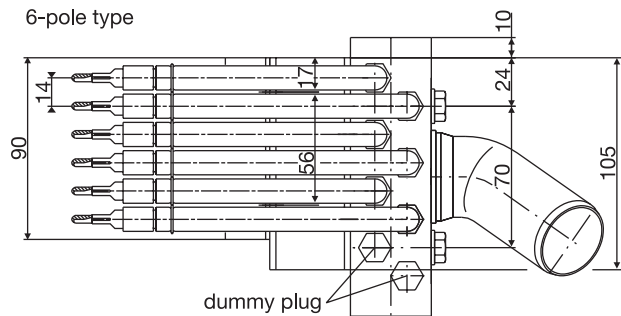



ACCESSORIES

The compact conductor rail cleaners are available for the same number of conductors as the compact current collectors. They have cleaning elements instead of carbon brushes.

They are installed like current collectors and clean the rail through the integrated suction nozzle. Cleaning elements must **not** be used for current collection for safety reasons.



Compact rail cleaners

As is mandatory for overhead monorail systems, pole no. 4 has a PE connection.

The following models are available:

Model	No. of poles	Order No.
ARDS 2 / 40-6-14	6 poles	142 549
ARDS 2 / 40-7-14	7 poles	142 604
ARDS 2 / 40-8-14	8 poles	142 540

Further models for different numbers of poles/conductors, conductor spacings and conductor rail systems upon request.



Conductor rail cleaner (single)

Model	Order No.
ARDS 2/40	142 541
ARDS 2/40 with PE connecting cable	142 542



Cleaning head

Model	Order No.
Cleaner head ARDSW 2/40	142 620

Accessories

Model	Order No.
Replacement filter bags	166 429
Spare hose (Ø12, 235 mm long)	142 582
Spare hose (Ø12, 250 mm long)	142 583
Spare hose to blower, (Ø40, 2 m long)	142 626
Side channel blower	142 624
Filter housing	142 625

Safety instructions:

- ▶ **Caution when handling live parts!**
Carbon dust is conductive and may cause short circuits!
- ▶ **On heavily soiled systems, the filter bag (inside the filter housing) needs to be replaced at short intervals!**
- ▶ **Do not inhale carbon dust!**
- ▶ **Filter bags may not be shaken out but must be disposed!**